

**INTERNATIONAL LTD
THERMAL RESEARCH**



Owner's Manual

**Diesel and Electric Heating System
for Recreational Vehicles**

International Thermal Research

IN CANADA:

**2431 Simpson Road
Richmond, BC, Canada V6X 2R2
Tel: 1-800-755-1272
or 604-278-1272
Fax: 604-278-1274
Email: info@itrheat.com**

IN THE UNITED STATES:

**Suite B, 11915 56th Circle
Vancouver, WA, USA 98682
Tel: 1-800-993-4402
or 360-993-4877
Fax: 360-993-1105**

*Website: **www.itrheat.com***

All rights reserved. No part of this manual may be reproduced or transmitted in any form by any means, electronic or mechanical, including photocopying and recording, information storage, retrieval, or transmission, without permission in writing from International Thermal Research

Right to Modify:

Due to our commitment for quality and ongoing product improvement, ITR reserves the right to modify or change without notice, any materials, applications, equipment, accessories, and/or prices. All measurements and weights are approximate.

Copyright © 2011 International Thermal
OASIS[®] is a registered trademark of International Thermal Research Ltd.

IMPORTANT

Warranty Registration Card

Owner's Name _____

Address _____

City _____ State/Prov. _____ Zip/Postal code _____

Telephone _____ Email _____

Motorhome Model _____

Date of Motorhome Purchase _____

Dealer's Name _____ City _____

OASIS Serial Number _____

Owner's Signature _____ Date _____

NOTE: This warranty card must be filled in completely, signed and returned to ITR within 30 days of the motorhome purchase. This warranty is not transferable by the owner. Make a copy of this page after completion and keep it for your records.

----- Fold Here -----

Place
Stamp
Here

International Thermal Research Ltd.

2431 Simpson Road, Richmond BC

Canada V6X 2R2

Toll Free: 1-800-755-1272

CUT HERE AND MAIL IN

Table of Contents

- Features of your OASIS Heating System.....7
- Operating Instructions for the OASIS Heating Module9
- Turning the Power to the OASIS Heating Module ON9
- Activating the Burner (Primary) and AC Heat (Secondary)
from the Remote Operating Panel9

- Activating the Cabin Fan Heaters through the Thermostats..... 10
- Activating the Domestic Hot Water 10
- Activating the Engine Heat & Preheat Function 11
- Functions of the Remote Operating Panel 11
- Functions of the Heating Module Control Panel 12
- Functions of the Distribution Module Zone Control Panel 13
- Maintenance 14
- Protecting the Heating Module and Distribution Module 15
- General Troubleshooting 15
- Customer Service Contact..... 16
- Warranty Information..... 17

Operating the Oasis[®]

This manual describes the features, operation and maintenance of your new OASIS Heating System. READ THIS MANUAL AND SAVE IT FOR REFERENCE.

Features of Your OASIS Heating System

The OASIS Heating Module uses a diesel burner (12 VDC) controlled by a multi-functional electronic controller as the primary source of heating coolant fluid (anti-freeze and water). Two 1500 Watt, 120 VAC immersion elements are used as secondary heat sources. The OASIS Heating Module heats the coolant fluid to provide a source of heat for all hydronic space heating needs. When used with the Distribution Module and its integral distribution pumps, the OASIS Heating Module has the ability to circulate the coolant fluid to all space heating areas. It can also provide a supply of domestic hot water using the integral heat exchanger in the Distribution Module.

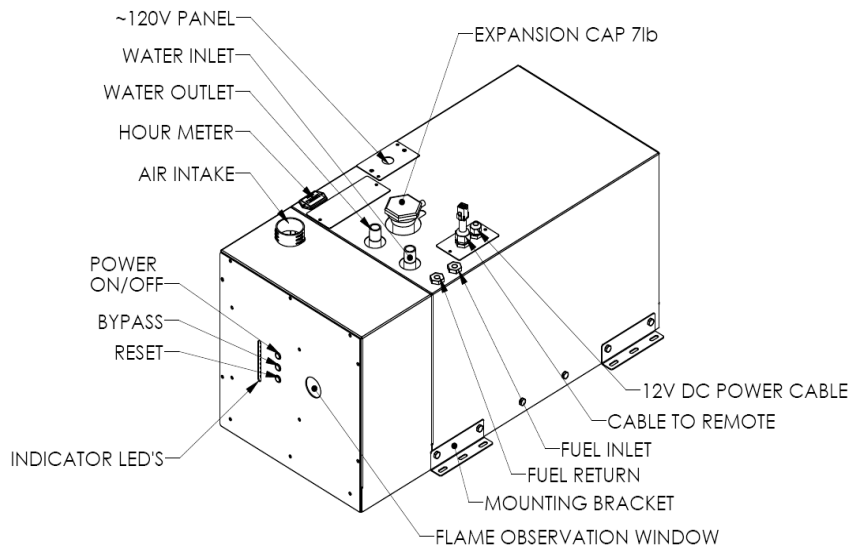

Other features of the Heating Module include:

- A high-temperature, stainless steel burner and stainless steel jacket.
- 8.2 US gallon welded stainless steel coolant tank that is insulated to minimize heat loss and optimizes heat recovery.
- Low coolant level switch on the tank.
- Easy to install, completely modular and field serviceable with Heating Module hookups and connections easily accessible from the front and top of the OASIS Heating Module.
- Quiet operation and low power consumption.
- Low pressure fuel system with built-in fuel pump.

- Fuel efficient burner capable of burning a wide variety of diesel-based fuels.
- Exhaust has minimal smoke and smell.
- Fan assisted sealed combustion is designed to use outside combustion air.
- Simple, low amperage draw ignition.
- Electronically-controlled system with:
 - Automatic safety shutdown.
 - Manual-reset aquastats for safety overheat protection.
 - LED indicators on the Control Panel for diagnostics.
 - Patented, proprietary Flame Sensor.
- Heating Module Remote Operating Panel with ON/OFF switch for the diesel burner, AC elements, and engine heat.
- Heating Module Control Panel with buttons for Power, Bypass, Reset, and indicator LED's for operational and diagnostic information;

The OASIS™ Distribution Module:

- Three distribution pumps, one heat exchanger for heating multiple zones, engine heat function, and also producing domestic hot water (mixing valve included). Also includes filling valves for easy filling/purging.
- Zone Control Board for controlling up to five space heating zones.

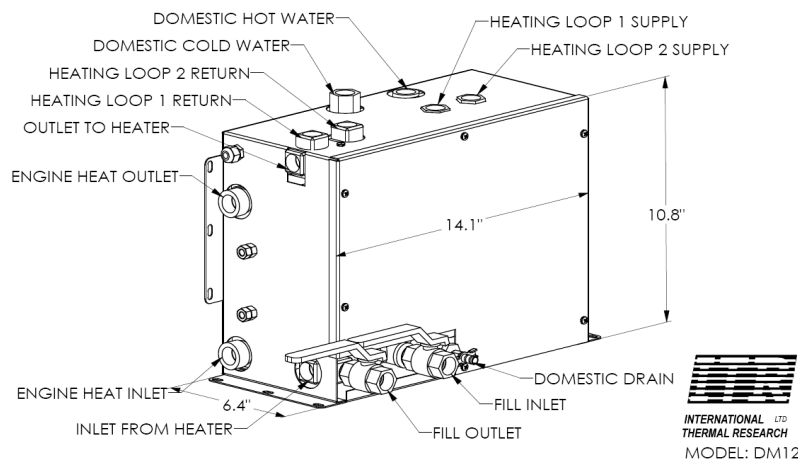

NOTICE

As the user, you must be fully aware of the controls and operating features particular to your model of The OASIS Heating Module. This is essential for the proper functioning and life of your OASIS Heating Module as well as protecting your warranty.

Your model can be identified by locating the serial number label on the outside case of the OASIS Heating Module. The serial number identifies the model type through the first series of letters and numbers.

Operating Instructions for the OASIS™ Heating System

The **OASIS™** Heating Module heats the coolant to a preset temperature and will automatically cycle to maintain the temperature. The heated coolant is then circulated by the Distribution Module.

Turning the Power to the OASIS™ Heating Module ON

- The OASIS Heating Module's main Control Panel, *Figure 8-2: Heating Module Main Control Panel*, located on the front of the module contains three push buttons: ON/OFF power, Bypass, and Reset. The power switch must be pushed ON (power LED will turn ON) to turn the DC electrical power to the main control board and module ON and is required to be left ON during any period where heat is requested.
- When the OASIS Heating Module is shut down for any extended period or the season, it is recommended that the power switch be turned OFF.

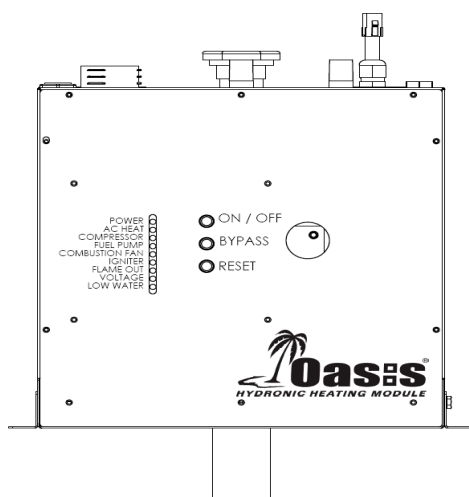

NOTICE

Do not operate the OASIS Heating System until a suitable water/anti-freeze solution is in the modules and all trapped air has been bled or removed. Do not operate the OASIS inside an enclosed building

! DANGER

Use only a non-toxic propylene glycol based coolant with additives generally recognized as safe "GRAS" by the FDA in the OASIS Heating Module and Distribution Module.

The OASIS exhaust is hot; do not park in areas such as tall dry grassy fields, as a fire may result.

Activating the Burner (Primary) and AC Heat (Secondary) from the Remote Operating Panel

Activating the Burner (Primary Heat Source)

- The burner switch on the Remote Operating Panel controls the ON/OFF of the diesel burner (primary heat source). When the burner switch is turned ON, the diesel

portion of the OASIS Heating Module will turn ON after ten seconds. The Burner LED will turn ON when the diesel burner has been activated. The burner will continue to operate until the coolant in the OASIS Heating Module reaches the set operating temperature range. At this point, the diesel burner will turn OFF. If the OASIS Heating Module coolant should cool down below this temperature range, the burner will again commence firing and will continue until either the burner switch on the remote panel is turned OFF or the temperature range is again achieved. If the burner switch on the remote panel is turned OFF, the burner stops and the OASIS Heating Module enters a two minute cool down stage prior to completely shutting down.

Activating the AC Immersion Element(s) (Secondary Heat Source)

- Place the AC power switch on the Remote Operating Panel to either the one element or the two element position. The AC Heat (green) LED will turn ON indicating the AC element(s) are energized and the coolant is being electrically heated. They will continue to operate until the coolant in the OASIS Heating Module reaches the set operating temperature range. At this point, the elements will turn OFF. If the OASIS Heating Module coolant should cool down below this temperature range, the AC elements will again be energized and will continue until either the AC switch on the remote panel is placed in the OFF position or the temperature range is again achieved. If the AC element switch on the remote panel is turned OFF, the AC elements are de-energized and the AC Heat (green) LED turns OFF.

Activating the Burner and AC Immersion Element(s) Jointly

- Turn the burner switch ON and place the AC power switch on the Remote Operating Panel to either the one element or the two element position. The Burner and AC Heat (green) LED's will turn ON indicating the diesel burner and AC element(s) have been selected.

Activating the Fan Heaters through the Thermostats

(Burner or AC Heat or Engine Heat Source Available)

- Any thermostat connected to the Distribution Module's Zone Control Board and calling for heat will cause the cabin fan controlled by that thermostat to be enabled. The ITR cabin fan has a built-in aquastat that prevents the cabin fan from blowing cold air. Once the room temperature has reached the temperature called for by the thermostat the cabin fan will turn off.

Activating the Domestic Hot Water

As long as heat is available in the OASIS Heating Module, the Distribution Module will respond to a call for domestic hot water. Ensure that a heat source has been selected (i.e. Burner, AC, Engine). The production of the domestic hot water is **continuous** on the Burner operation and **limited** when using AC or Engine.

NOTICE

The domestic water pump is not a part of, nor controlled by the Distribution Module or The OASIS™ Heating Module.

Activating Engine Heat & Pre-heat (If Option is installed)

Pre-heating the Engine

- Turn the engine preheat switch on the Remote Operating Panel to the ON position with the burner or AC switch on. The engine preheat pump and coolant pump will be activated once the OASIS Heating Module is in its set operating temperature range. The engine will start to be preheated by the OASIS Heating Module.
- Note: An engine preheat pump does not come supplied with the Distribution Module. The power and ground for the pump is available from the Distribution Module.

Engine Heat Used for Domestic Water or Space Heating

- Start the vehicle engine and let it come up to the normal operating temperature. Turn the burner switch on the Remote Operating Panel to the ON position. The OASIS Heating Module will come up to the set operating temperature range and will cycle OFF. The heat from the vehicle engine will be transferred from the engine to the domestic water and space heating loop.

Functions of the Remote Operating Panel

- The OASIS Heating Module's Remote Operating Panel contains one ON/OFF burner switch, one triple position AC element switch, one ON/OFF engine heat switch to control the optional engine pre-heat pumps, and four LED's indicating Burner activation, AC element activation module fault, and zone fault.

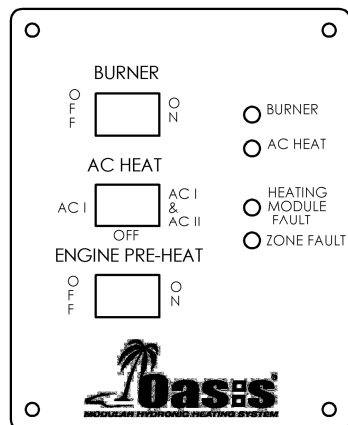

Burner Switch (Primary Heat Source)

- The burner switch on the remote panel controls the ON/OFF of the diesel burner. The Burner LED will turn on when the diesel burner has been activated.

AC Element Switch (Secondary Heat Source)

- The triple position AC element switch controls the activation of a single 120 VAC immersion element only, dual 120 VAC immersion elements jointly, or both elements off. The AC heat LED will turn ON to indicate when the element(s) have been activated.

Engine Pre-Heat Switch (If this Option is installed Only)

Preheating the Engine

- The engine pre-heat switch (optional) controls the ON/OFF of the engine pre-heat pump (not included). However, the engine pre-heat pump (not included) will not function unless the coolant in the OASIS Heating Module has achieved a preset temperature.

Burner LED (Green)

- When ON, indicates the diesel burner has been activated.

AC Heat LED (Green)

- When ON, indicates the 120 VAC immersion element(s) are activated.

Module Fault LED (Red)

- When ON, indicates the OASIS™ Heating Module has faulted. The specific fault can be identified by examining the OASIS™ Heating Module Control Panel located on the front of the OASIS™ Heating Module. There are indicator LED's on the panel that are used for diagnostics. Refer to the description of the OASIS Heating Module Control Panel for further details.

Zone Fault LED (Red)

When ON, indicates the space heating zone(s) has faulted. The specific fault can be identified by examining the Distribution Module Zone Control Panel (optional) located beside the OASIS Heating Module. There are indicator LED's on the panel that indicate the problem. Refer to the description of the Distribution Module Zone Control Panel for further details.

Functions of the Heating Module Control Panel

- The OASIS Heating Module's Control Panel contains three push buttons: ON/OFF power, Bypass, and Reset. In addition, it contains nine LED's indicating Power, AC Heat, Compressor, Fuel Pump, Combustion Fan, Igniter, Flame Out, Voltage and Low Water.

Power Button

- The power button turns ON/OFF the power to the control board. The Power LED (green) turns ON when the power to the control board is ON.

Bypass Button

- The bypass button is for **authorized service personnel only**.

Reset Button

- The reset button when pressed resets the control board.

Power LED (Green)

- The power LED (green) turns ON when the power to the control board is ON. The LED flashes when the OASIS™ Heating Module is in Bypass mode.

AC Heat LED (Green)

- The AC Heat LED (Green) turns ON when a single or dual AC immersion element(s) have been activated.

Compressor, Fuel Pump, Combustion Fan, Igniter (Green)

- The compressor, fuel pump, combustion fan, and igniter LED's (Green) turn ON when the component is ON, and will flash if the component is electrically open or shorted.

Flame Out (Red)

- The Flame Out LED (Red) turns ON when a flame fault has been detected.

Voltage Fault (Red)

- The voltage fault LED (Red) turns ON when a voltage fault has been detected.

Low Water (Red)

- The Low Water LED (red) turns ON when a low coolant level in the OASIS Heating Module has been detected.

Functions of the Distribution Module Zone Control Panel

- The Distribution Module Zone Control Panel contains seven green LED's for *Power, Zone 1, 2, 3, 4 and 5 Thermostat(s), and Domestic Water.*
- It also contains nine matched pairings of red/green LED's for *Zone 1, 2, 3, 4 and 5 Fan(s), Summer Loop, Heat Loop 1, Heat Loop 2, and Engine Pre-heat Pump.*

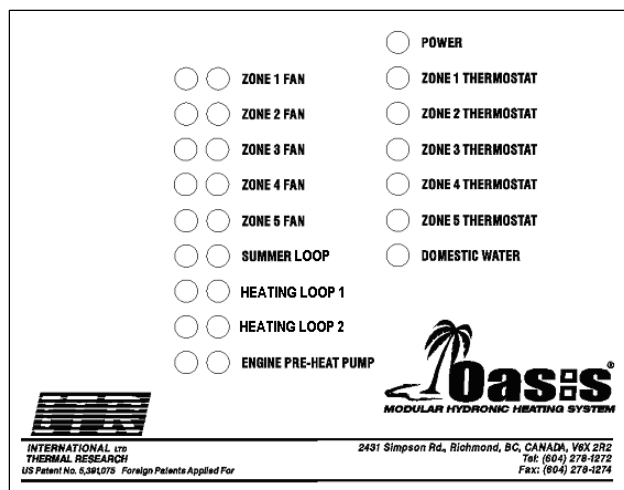

Power LED (Green)

- The power LED turns ON when the power to the Zone Control Board is ON.

Zone 1, 2, 3, 4, 5 Thermostat LED's (Green)

- The Zone # LED turns ON when the thermostat in the zone is calling for heat.

Domestic Water LED (Green)

- The domestic water LED turns ON when there is a call for domestic water heat.

Zone 1, 2, 3, 4, 5 Fans, Summer Loop, Heat Loop 1, Heat Loop 2, Engine Pre-heat Pump Paired LED's (Red/Green)

- The nine paired LED's indicates the functionality of the devices. The green LED will turn ON when the device is operating normally. The red LED turns ON if a fuse has been blown.

Maintenance

Customer Monthly Maintenance: Check the following and correct as required:

- Coolant hoses and fittings for leaks and integrity.
- Check coolant level in the overflow bottle (3/4 full when hot). **Fill only when the system is COLD and in small quantities only to prevent overfilling.**
- Exhaust fittings, connections, tubes for leaks, and integrity.
- Exhaust and air-intake checked for no obstructions.
- Fuel lines, fittings for leaks and integrity.
- External fuel filter for clogging.

Annual Service Requirements: Perform the following:

- **Prior to operation for the season, a factory service tune-up of the modular system should be performed by trained service personnel.** Only personnel familiar with the equipment modules should perform the service tune-up. It is recommended that the dealer be contacted for this service or if not available, contact ITR for information on service resources.
- As a general guide, the regular maintenance items such as the igniter, fuel filters (internal and external), and air filter (internal) should be replaced as opposed to inspected and cleaned. Their performance may be deteriorating and/or their remaining service life ending without any apparent visual signs or operating symptoms.
- The major components such as the air compressor, fuel pump, fuel nozzle, and combustion air fan should be examined for wear and should be replaced by the service technician as required.

- The combustion tube should be inspected by the service technician for wear and replaced if necessary. To access the combustion tube, the front panel of the OASIS must be removed along with the burner box cover. The fuel block must then be removed from its mounting position. Finally, the burner and counter-flow tube must be taken out by removing the nuts holding the burner box in position. If the tube is satisfactory, a thorough cleaning of the tube and burner chamber should be performed by blowing out and vacuuming any ash and carbon buildup. Any build up on the surface of the burner chamber will cause the heater to lose efficiency.
- Regular inspection and maintenance is the only way to ensure safe, reliable and efficient operation of your heating system.

Protecting the OASIS Heating System

NOTICE

Protect the OASIS Heating Module and Distribution Module from temperature extremes and any dusty, dirty, corrosive environment.

! DANGER

Protect the module(s) and the system from cold temperatures and corrosion by using a proper mixture of anti-freeze and water. Use only a non-toxic propylene glycol based coolant with additives generally recognized as safe "GRAS" by the FDA in the OASIS Heating Module and Distribution Module (Optional). Read and follow the anti-freeze manufacturer's instructions for the type of anti-freeze and mixture recommended for your application.

NOTICE

Note that any domestic water in the Distribution Module will freeze in cold temperatures and will damage the internal parts. The Distribution Module and all associated components must be completely drained and emptied of any domestic water before freezing temperatures are encountered.

General Troubleshooting

Ensure that your heating module has both sufficient battery voltage and ground, and coolant level as the module is designed not to allow operation if either are incorrect (indicated by lit Voltage LED or Low Water LED on the OASIS Heating Module Control Panel) .

Burner Does Not Start Up

- OASIS Heating Module connected to 12 VDC power?
- Power button on OASIS Heating Module Control Panel pushed ON? Power LED lit on OASIS Heating Module Control Panel?
- Burner switch on Remote Operating Panel ON? Burner LED lit on Remote Operating Panel?
- Main fuse or circuit breaker blown or tripped?

AC immersion elements do not activate

- Module connected to 120 VAC power? Circuit breakers tripped?
- AC switch on Remote Operating Panel placed in the one or two element position?
AC Heat LED lit on Remote Operating Panel?

Burner Starts but Flame Faults

- Fuel supply present and adequate?
- Air-intake or exhaust not blocked or obstructed?
- Air in fuel line (white smoke from exhaust or popping sound from exhaust)?
- Fuel filter (external) dirty?
- Restrict the fuel return line with needle valve or pinch off completely.

Burner Starts but Zone Faults

- Power LED on Distribution Module Zone Control Panel glowing green?
- Component matched LED pairings all glowing green on the Zone Control Panel?

Customer Telephone / Email Service

If you have a service problem, first check the *Troubleshooting* section of this *Owner's Manual* to determine if your problem is addressed. Also ensure you are familiar with the design and installation setup. When calling ITR or the Authorized Service Dealer with a problem, have the following information ready at hand:

- model number and serial number of the Product
- a detailed description of the problem
- your *Installation Manual* and/or *Owner's Manual*

You must obtain written approval from ITR or the Service Dealer for any warranty repair before it is undertaken. All repairs done under warranty are subject to the terms and conditions of the flat-rate manual. There is no charge for help or service information given over the telephone or by fax or email. However, any informal advice or recommendation from ITR employees or its dealers is given only in good faith as an accommodation to the customer. Such information should not be relied upon without an independent verification of its applicability to the customer's particular situation. For further information contact:

IN CANADA:

2431 Simpson Road

Richmond, BC, Canada V6X 2R2

Tel: 1-800-755-1272 or 604-278-1272

Fax: 604-278-1274

IN THE UNITED STATES:

Suite B, 11915 56th Circle

Vancouver WA USA 98682

Tel: 1-800-993-4402 or 360-993-4877

Fax: 360-993-1105 Email: info@itrheat.com

Warranty Information

Warranty cards must be filled in completely, signed by the Owner and Dealer and returned to ITR within 30 days of the date of the initial "in-service" date.

General Warranty

ITR warrants the OASIS® CH50, AND OASIS® COMBI (referred to as "heater(s)") DISTRIBUTION MODULE and all accessories or other supplied components with the original purchase to be free of defects in materials and workmanship under design usage and service conditions for ONE (1) year from the heater "in-service" date. Warranty replacement parts are covered for the remainder of the heater's warranty.

Limited Warranty

The following warranties are in lieu of all other warranties and conditions. ITR makes no other warranties, representations, or conditions, express or implied. Expressly excluded are all implied or statutory warranties or conditions of merchantability of fitness for a particular purpose, and those arising by statute or otherwise in law or from dealing or trade usage.

The stated express warranties are in lieu of all liabilities or obligations for damages arising out of or in connection with the delivery, use, performance, or licensing of the Product or in connection with any services performed. In no event whatsoever will ITR be liable for indirect, consequential, exemplary, incidental, special, or similar damages, including but not limited to, lost profits, lost business revenue, failure to realize expected savings, other commercial or economic loss of any kind or any claim against ITR by any other party arising out of or in connection with the sale, delivery, use, performance, or repair of the Product, or in connection with any services performed, even if ITR has been advised of the possibility of such damages, whether based upon warranty, contract, or negligence. ITR's maximum liability shall not in any case exceed the contract price for the Products claimed to be defective.

No one is authorized to increase, alter, or enlarge ITR's responsibilities or obligations under these warranties.

Owner's Responsibilities

If any warrantable failures occur before the expiration of the warranty, the Owner must give notice of such failures to ITR or to the authorized ITR dealer from which the Product was originally purchased, and obtain written approval for the warranty repair.

The Owner is responsible for the following costs in case of a warrantable failure:

- shipping and insurance costs to deliver the defective Product to the dealer or ITR (if necessary)
- all repairs made to equipment ancillary to the Product, including the vehicle, coach engine, and other associated components of the vehicle in which the Product is installed

- lodging, meals, and other incidental expenses incurred by the Owner as a result of a warrantable failure
- “down time” expenses and all business costs and losses resulting from the warrantable failure

Not Covered Under Warranty

Warranty will be voided or not extended in the following circumstances:

- Owner fails to notify ITR or the authorized ITR dealer from which the Product was originally purchased about a warrantable failure and to obtain prior written approval for warranty repair.
- Original serial number on Product or electrical control board has been removed, altered, or is unreadable.
- Product has been modified or uses non-standard parts not approved by ITR.
- Product has been abused (such as by dropping it), damaged, vandalized, or has received improper maintenance.
- Product has been run dry or operated without appropriate antifreeze; causing damage to the heat exchanger, pump seals, etc.
- Product has been exposed to an environment detrimental to its effective operation, such as excessively wet, dirty, or hot areas.

Also not covered under warranty:

- Parts or Products no longer within the manufacturer’s warranty period.
- Parts or Products installed or used in a manner contrary to ITR’s printed instructions without ITR’s prior written permission.
- Normal wear and tear of parts, including but not limited to, fuel filter, air filter, nozzles, fuses, ignitor, electrical motors, fuel pumps, air compressors, and carbon brushes.
- Product malfunctions due to improper installation of parts or Products, including but not limited to malfunctions causing inadequacies in air, fuel, or coolant flow; voltage problems due to improper wiring; and shock or vibration.
- Progressive damage to the engine or vehicle caused by failure of the Product or an improper installation.
- Diagnosis or repairs to fix problems not directly related to the Product or due to empty fuel tanks or poor fuel quality, fuel additives, acidic water, electrolysis, or any chemical reactions.
- Travel time and expenses by an ITR dealer.
- Removal and re-installation expenses for the ITR heater.

Returns

If a service call by an authorized service person is not feasible, the Owner must do the following to obtain warranty service:

1. Immediately contact ITR (or your Dealer) and provide a full description of the problem.
2. Obtain (in writing) a Return or Repair Material Authorization (RMA) number from ITR for any warranty, return, repair, or service. ITR will refuse any return package and will not authorize service or repairs without a RMA number. (For repairs by authorized Dealers, the dealer must obtain an authorized RMA number from ITR before warranty work commences.)
3. When shipping your Product, pack securely, show the RMA and serial number of the Product on the outside of the shipping container, and ship prepaid and insured.
4. Provide written details of the problems, date of installation, proof of purchase, and a return address.

After repair or replacement of the Products still under warranty, ITR will pay return shipping charges. Factory repairs or replacement will be done as quickly as possible, with an estimated turnaround of five working days. All repairs done under warranty are subject to the terms and conditions of the flat-rate schedule.

OWNER'S SERVICE LOG:

Date	Service Performed	Service Center



International Thermal Research Ltd.

Copyright © 2011 ó All Rights Reserved